

FSDSCT20 Flat Screen Wall Mount

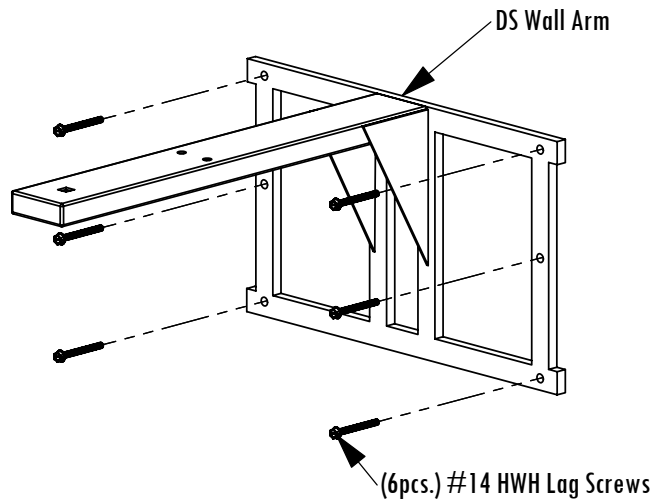

1. Determine the best possible viewing location for the monitor. If installing in wood stud, find two wood studs on 16" centers and mark the location of the DS Wall Arm mounting holes. For Concrete installations, order our WMAAB6, concrete anchor bolts. For Metal Stud installations, order our WMATB6, toggle bolts.

2. Drill pilot holes for the Lag Screws using a 1/8" drill bit, 2-1/2" deep, for each of the six mounting hole locations.

3. Attach the DS Wall Arm to the wall using the provided Lag Screws.

4. Apply thread locking agent to the male threads of the 1-1/4" Hex Bushing. Screw the 1-1/4" Hex Bushing into the 1-1/2" - 1-1/4" Hex Bushing Reducer at least 3/4".

5. Attach the Hex Bushings to the DS Wall Arm with the Socket Head Bolt, Washers and Nylock Jam Nut in the order shown. Tighten the Nylock Jam nut until the Hex Bushing is tight against the DS Wall Arm, but still able to swivel on the Nylon Washers.

6. Secure the Hitch Pin through the hole in the end of the Socket Head Bolt.

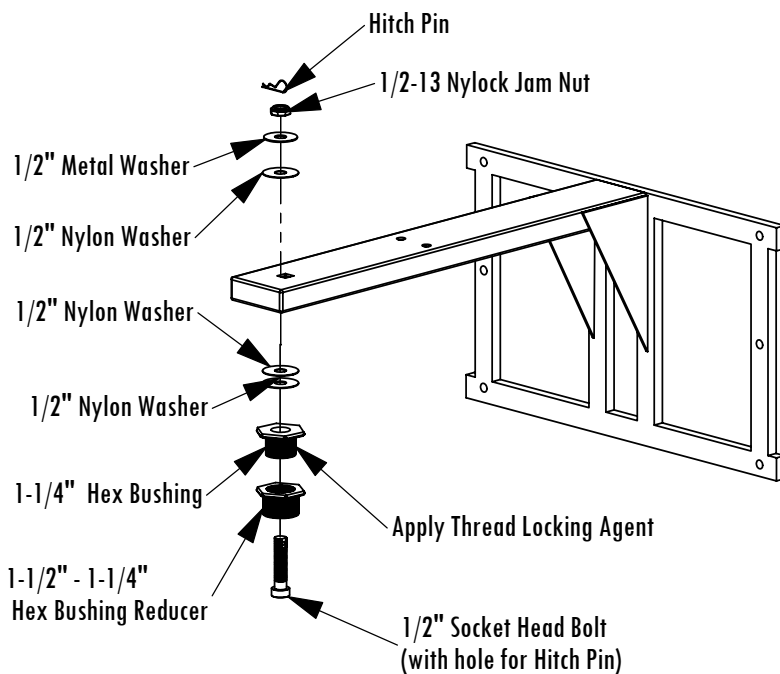

Hardware List

#14 HWH Lag Screws	6
Hitch Pin	1
1/2-13 Nylock Jam Nut	1
1/2" Metal Washer	1
1/2" Nylon Washers	3
1-1/4" Hex Bushing	1
1-1/2" - 1-1/4" Hex Bushing Reducer	1
1/2" Socket Head Bolt	1
Tube of Thread Locking Agent	1
1/4-20 x 1" SHC Screws	4
1/4" Flat Washers (Black)	4
5/16-18 x 3/4" Hex Bolts	4
5/16" Flat Washers (Black)	4
5/16-18 Nylock Nuts (Black)	4

Protected under one or more of these U.S. Patent numbers: 3,291,432; 3,559,942; 3,724,798; DES,270,689; 4,613,109; 4,878,645; 4,852,842; DES,309,5024; 973,023; 5,169,114; 5,255,884; 5,310,132; 5,522,576; 5,621,014; Re.35,677; DES,398,834; 5,826,384; 5,941,492; 5,964,068; 6,060,661; 6,102,398; 6,138,704; 6,454,110B1; 6,701,270B2; 6,806,425B1

FSDSCT20 Flat Screen Wall Mount

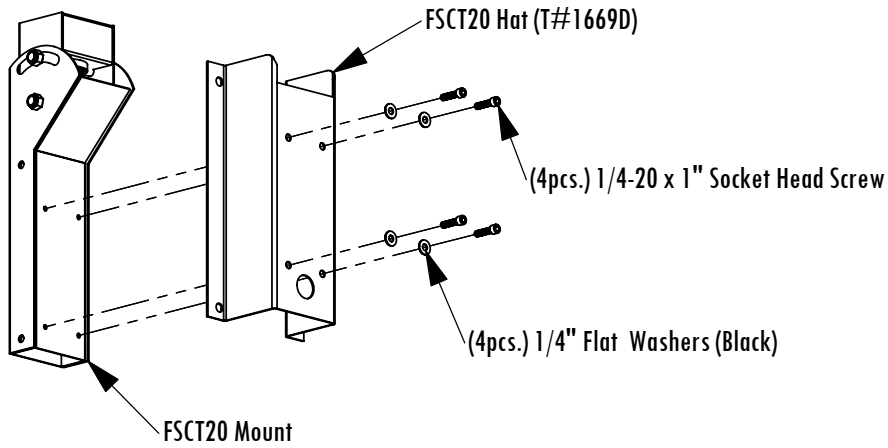

7. Connect the FSCT20 Hat to the FSCT20 Mount using the Socket Head Screws and Washers as shown.

8. Apply thread locking agent to the female threads of the coupling in the FSCT20 Mount. Screw FSCT20 onto the Hex Bushing Reducer at least 3/4".

9. Use the Hex Head Bolts, washer and Nylock Nuts as shown to bolt the Adaptor Plate (sold separately) to the FSCT20 Hat.

10. Double check to make sure all fasteners are tight and secure. Refer to the specific Adaptor Plate instructions for monitor mounting information.

