



LC200WA2

ARTICULATING WALL MOUNT FOR FLAT SCREENS UP TO 32"



Articulating wall mount with up to 200mm x 200mm VESA® mounting patterns. Features dual articulating pivot points, 180° swivel from wall arm and $\pm 45^\circ$ tilt (may be limited by size of monitor). For wood, metal or concrete wall mounting applications.

- Allows "Landscape" (horizontal) or "Portrait" (vertical) mounting of the monitor.
- Carton Dimensions:
15" L x 12" W x 4" H
- Projection from wall: 2-3/4" – 12"
- Gloss Black or Silver finish.

Load Limit	Swivel	Tilt	Ship. Wt.
50 lbs	180°	$\pm 45^\circ$	6.3 lbs



The Installers Choice

2744 East Eleventh Street
Oakland, CA 94601
1•800•LUCASEY or 510•534•1435
www.lucasey.com

LC200WA2

Product Data Sheet

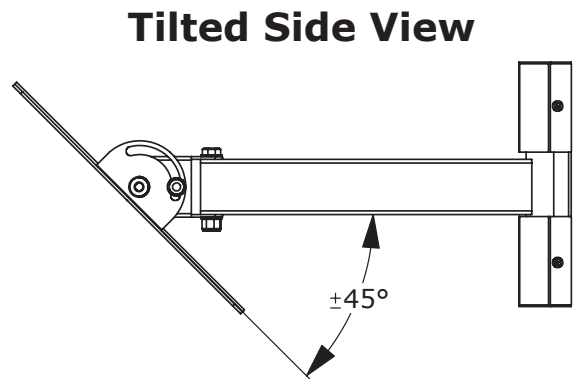
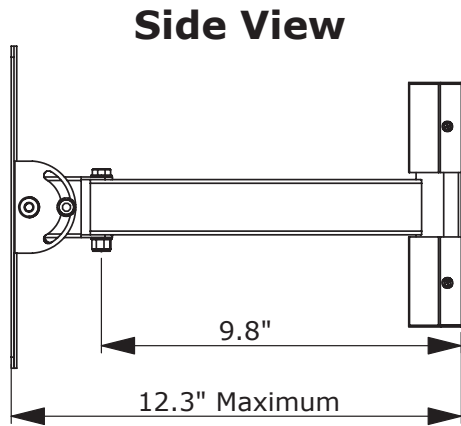
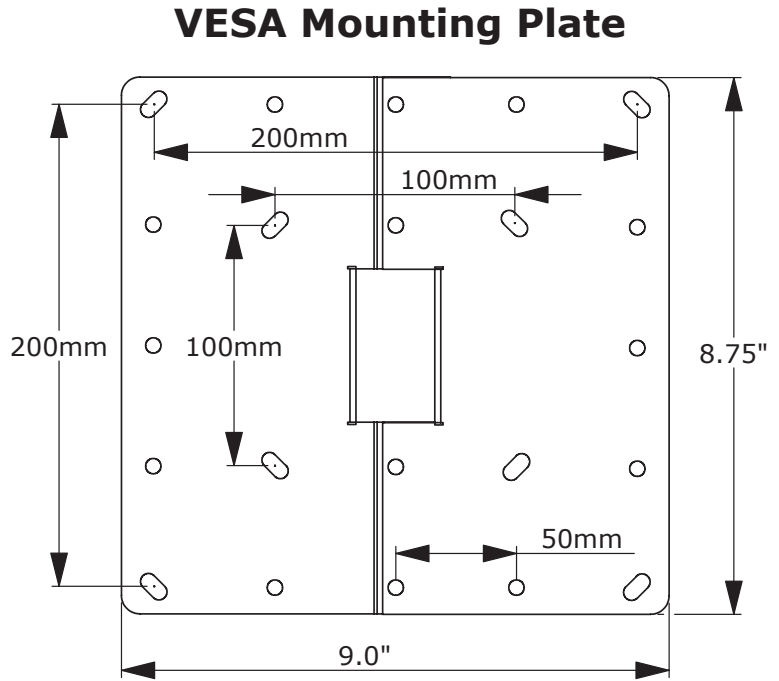
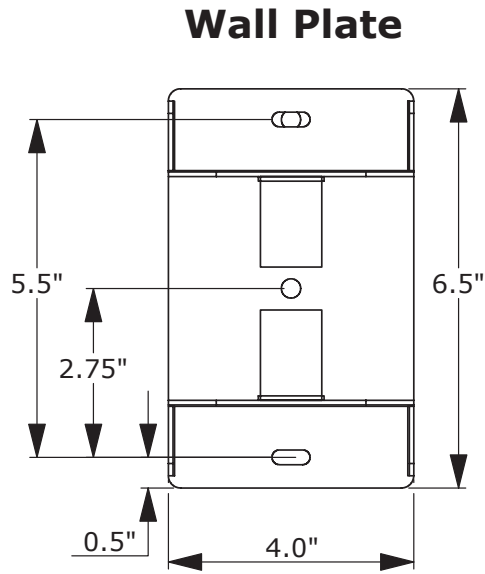

Max. tilt restricted by monitor size and/or distance from the wall

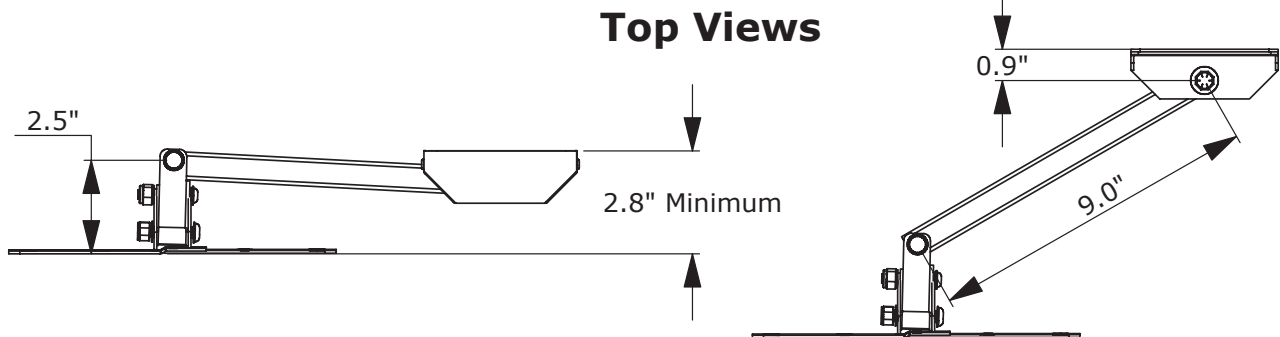

Visit lucasey.com for full product line details and technical info

Protected under one or more of these U.S. patent numbers: 3,291,432; 3,559,942; 3,724,798; DES.270,689; 4,613,109; 4,852,842; 4,878,645; DES.309,562; 4,973,023; DES.322,210; 5,169,114; 5,255,884; 5,310,152; 5,522,576; 5,621,614; Re.35,677; DES.398,834; 5,826,384; 5,941,492; 5,964,068; 6,060,661; 6,102,348; 6,158,704; 6,454,116B1; 6,761,276B2; 6,806,425B1; 6,926,244B1; 6,964,399B1; 6,988,698B2; 6,988,714B2.

© 2009 LUCASEY MANUFACTURING CORPORATION, Oakland, California. All rights reserved.