

LC200WT Security Wall Mount with Tilt for up to 32" Flat Screens

The LC200WT Security Wall Mount with Tilt is designed to secure up to a 32" flat panel monitor to the wall while still allowing the monitor to tilt.

The VESA® mounting patterns on the front of the LC200WT allow it to be mounted to monitors that have mounting patterns of 200mm x 100mm and 100mm x 100mm.

Convenient cutouts for electrical and A/V wiring in the wall.

The security screws provided with the mount can be used to prevent easy removal of the monitor without having the appropriate security tool (purchased separately). Standard socket head screws are also provided to mount the monitor without using the security hardware.

Our mounts are tested at four times the rated load limit to ensure that they can hold the monitor during seismic or other extreme loading events.

Important! Please read all warnings and cautions before installing the mount.

Caution: Improper installation of this mount may void the warranty on your monitor.

Caution: Wall attachment should be performed by qualified installers only, using construction methods prescribed by authorized architects or engineers that comply to all applicable codes and standards.

The maximum weight of monitor to be installed on the LC200WT is 75 Lbs. (34.1Kg.)

Inspect all parts to make sure there is no shipping damage. Do not install if any parts are damaged.

Please call 1-800-LUCASEY or 1-510-534-1435 if you have any questions about this installation.

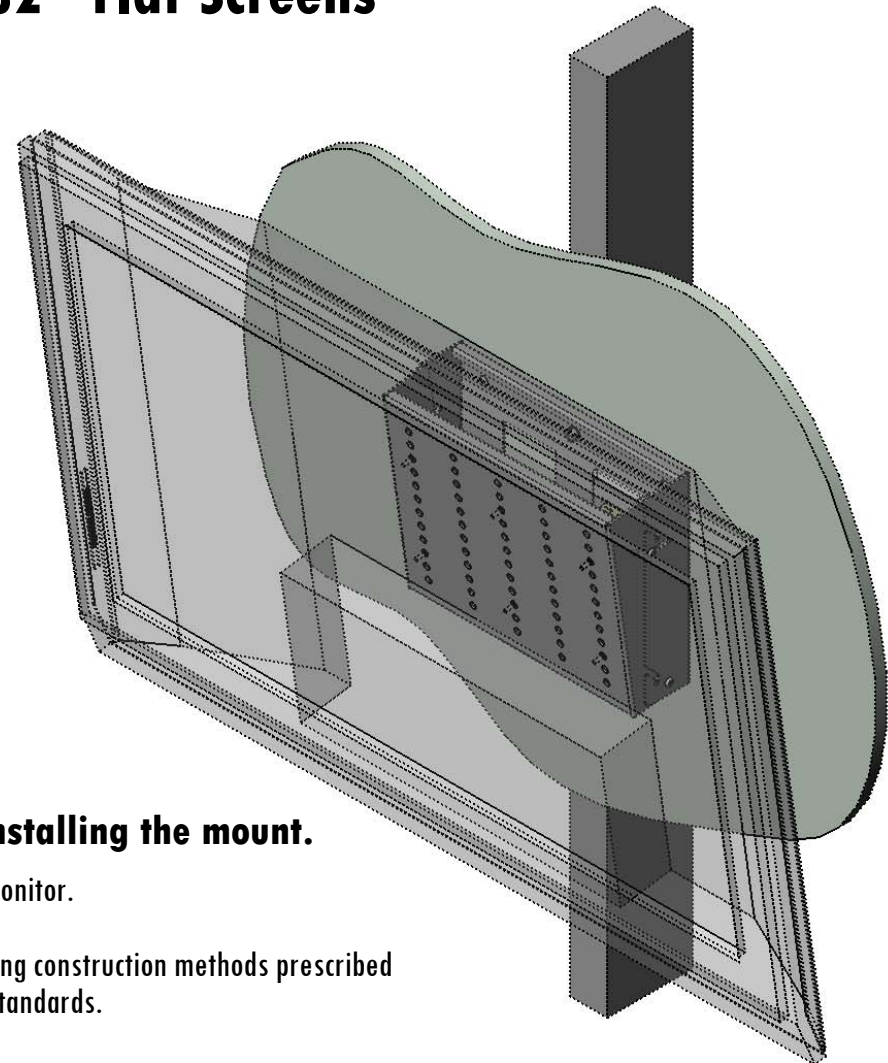

Protected under one or more of these U.S. Patent numbers: 3,291,432; 3,559,942; 3,724,798; DES.270,689; 4,613,109; 4,878,645; 4,862,842; DES.309,5624,973,023; 5,169,114; 5,255,884; 5,310,152; 5,622,576; 5,621,614; Re.35,677; DES.398,834; 5,826,384; 5,941,492; 5,964,068; 6,060,661; 6,102,398; 6,156,704; 6,454,11681; 6,761,27682; 6,806,425B1

LC200WT VESA® Front

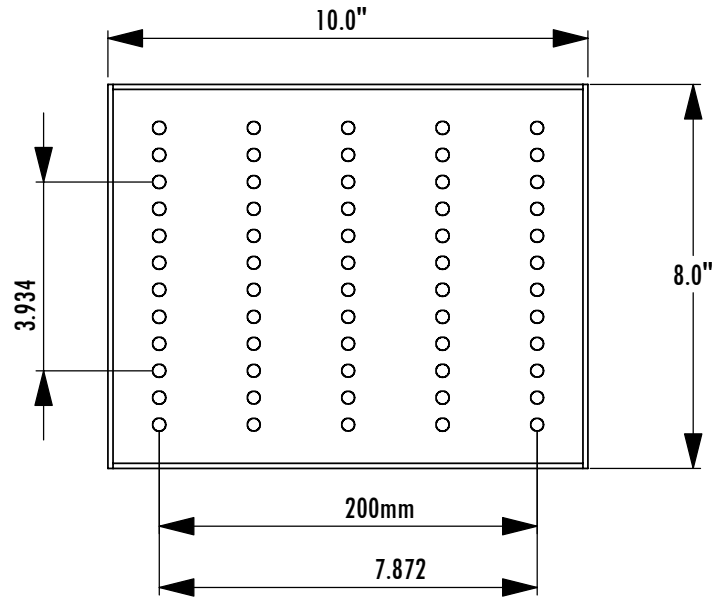

LC200WT Side View

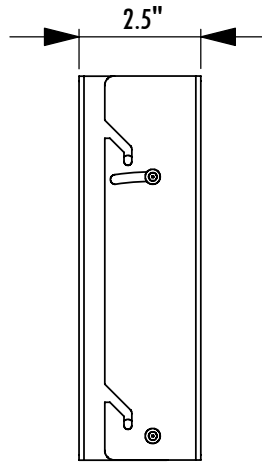

LC200WT Isometric View

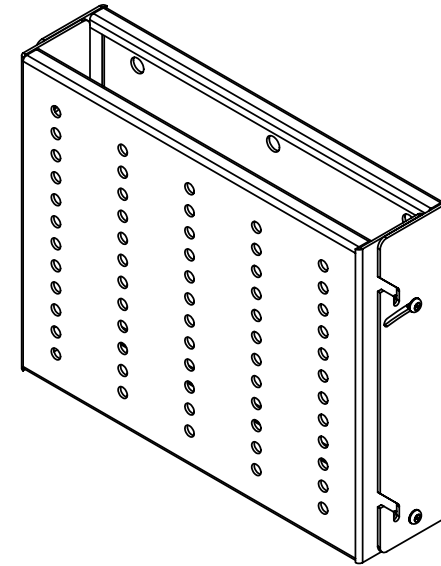

LC200WT Back Plate

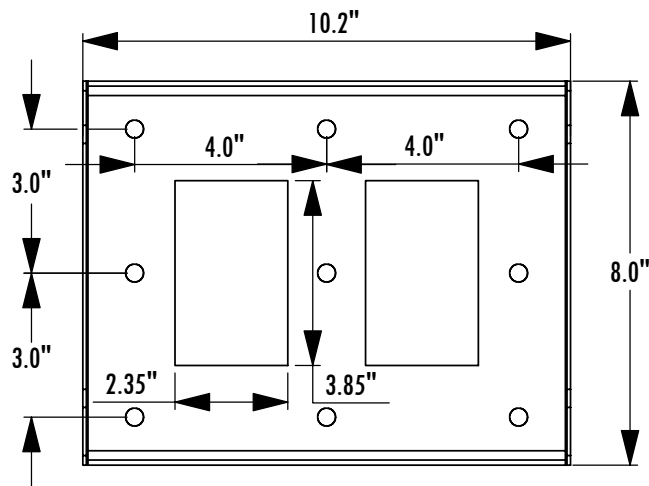

LC200WT Tilted

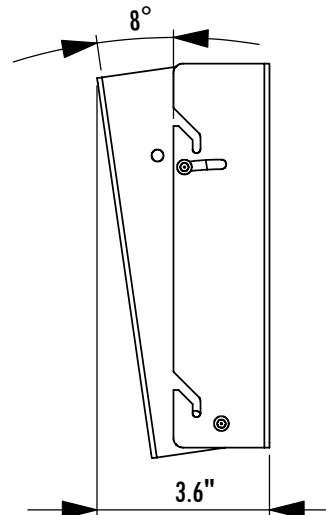

LC200WT Top View

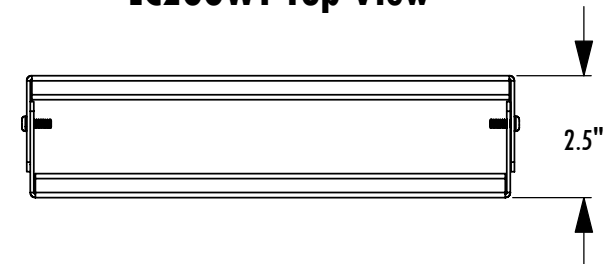

Monitor Attachment to Front Plate

Determine which type of monitor attaching hardware is required for the monitor as specified by the monitor manufacturer. Various sizes of monitor attaching screws are provided for convenience.

Make sure the top of the LC200WT Front is oriented in the same direction as the top of the monitor. The holes on the side of the LC200WT Front Plate are closer to the bottom edge than the top edge.

Align the LC200WT front plate with the VESA mount pattern on the back of the monitor. Attach the LC200WT Front Plate to the back of the monitor using the appropriate size screws and washers.

Make sure all of the Monitor Attaching Screws are tight before proceeding with the rest of the installation.

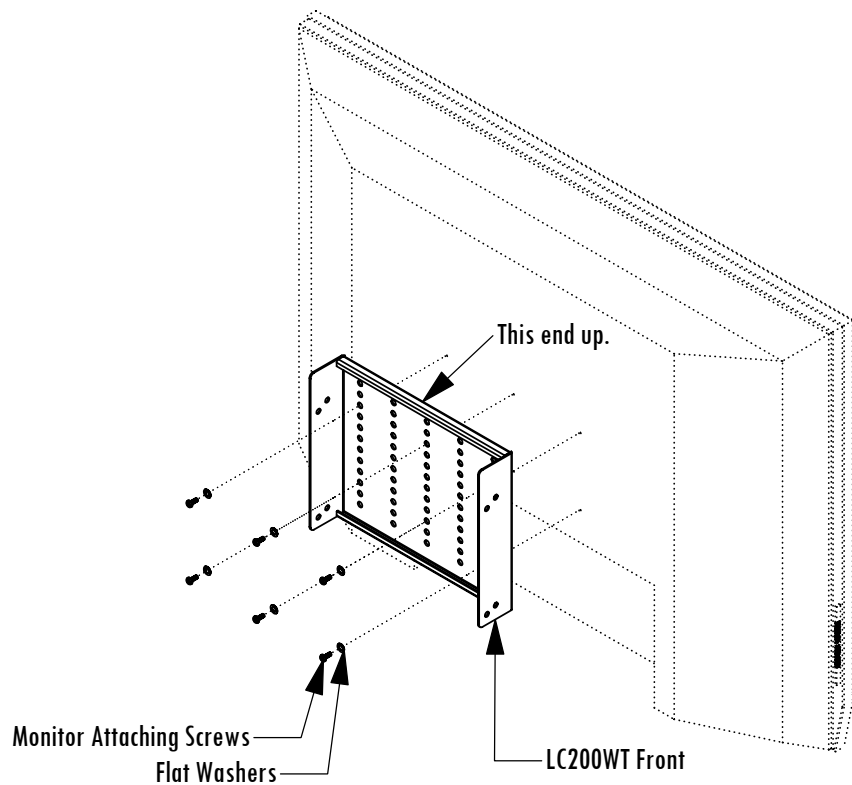

Attaching Front Plate to Back Plate

Screw four of the provided Socket Head Screws into the threaded inserts closest to the monitor on the LC200WT Front. Leave 1/2" of thread exposed.

With two people, lift the monitor, with attached LC200WT Front, onto the LC200WT Back making sure that the Socket Head Screws are engaging the Mounting Slots.

Using a long extension and the appropriate security socket tool or socket head driver, insert the Tilt Adjusting Screws and Pivot Screws into the threaded inserts farthest from the monitor.

Remove the Socket Head Screws, only after making sure the Tilt Adjusting Screws and Pivot Screws are installed. Adjust the tilt to the desired viewing angle and tighten all four screws.

Note: Security Screws and Socket Head Screws are provided for convenience. Either can be used to safely install the mount.

