

# LG2085B - Bolt Down Furniture Mount

for LG Models 32LC50C, 32LC5DC & 32LC7DC  
with fixed or swivel bases

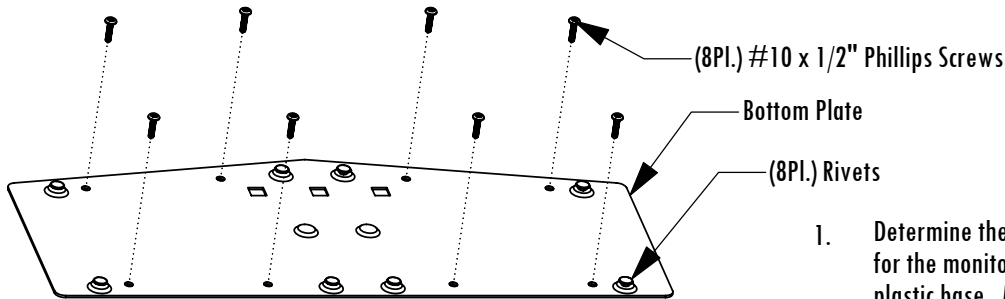

### Fixed Non-Swivel Base (6 Rubber Feet)

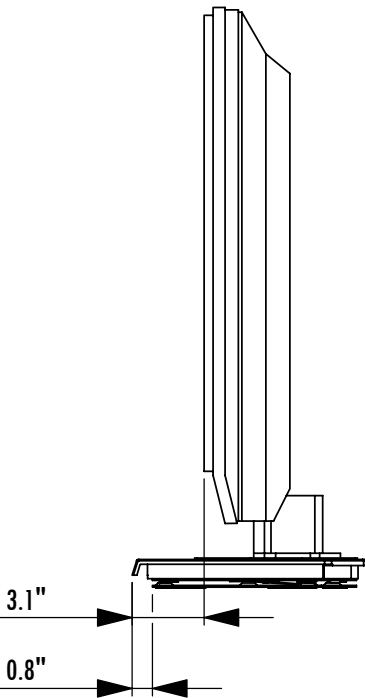
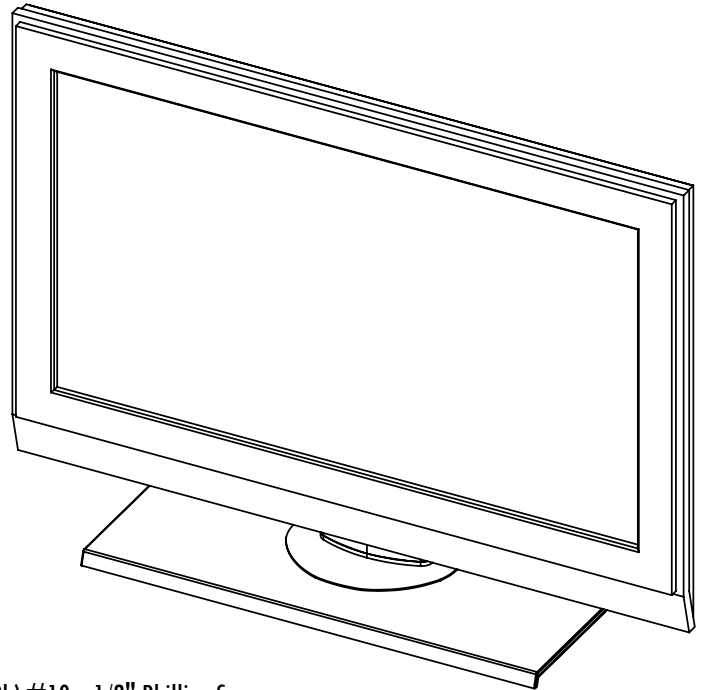
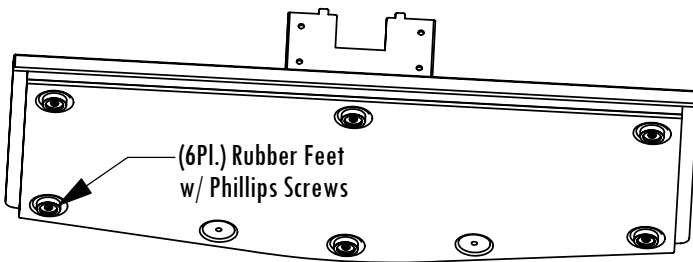

### Swivel Base (7 Rubber Feet)

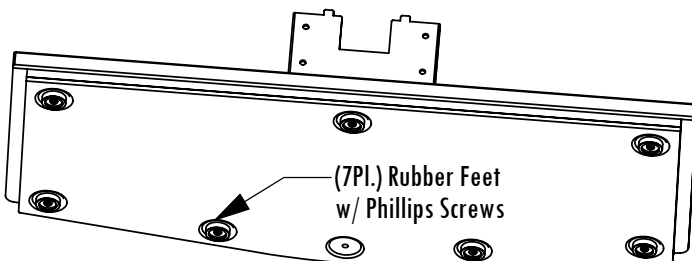

1. Determine the appropriate location on the furniture for the monitor. Mark the front edge of the monitor's plastic base. Mark a parallel line 3/4" back from the previous line.
2. Carefully line up the front edge of the Bottom Plate with the second line marked in step 1.
3. Attach the Bottom Plate to the furniture with the provided #10 x 1/2" Phillips Tapping Screws
4. Remove the rubber feet from the LG Monitor Base. The Swivel Base has 7 feet and the Fixed Non-Swivel Base has 6 feet.

### Component List

1. Top Plate
1. Bottom Plate
4. Security Screws
- 8 #10 x 1/2" Phillips Tapping Screws

**Step 5: Fixed Non-Swivel Base**

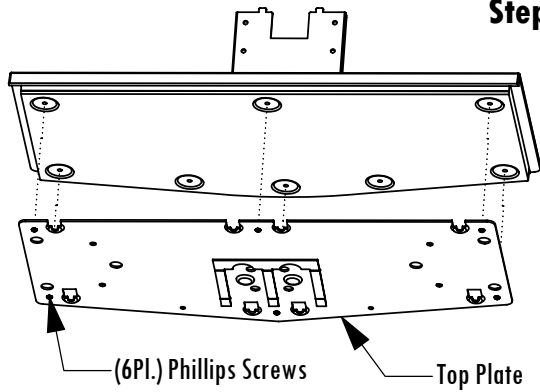

5. Attach the Top Plate to the Monitor Base with the screws removed from the feet.
6. Align the slots on the Top Plate Assembly from step 7 with the rivets on the Bottom Plate. Pull forward on the Top Plate Assembly to lock the two plates together.
7. Attach the LG monitor to the Monitor Base with the provided Security Screws.

**Step 5: Swivel Base**

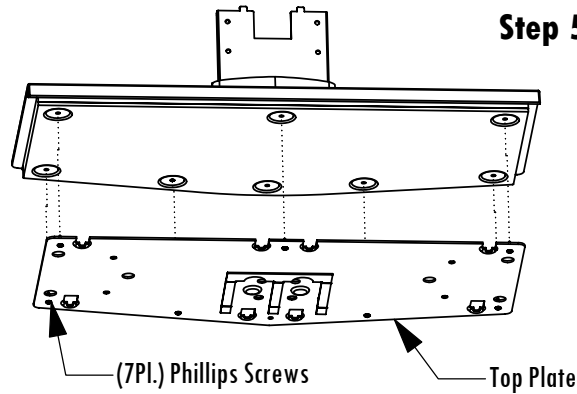

**Step 7**

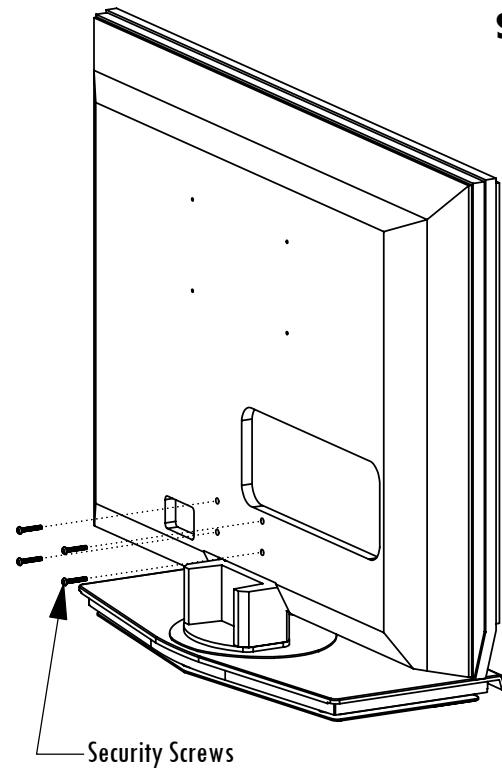

**Step 6**

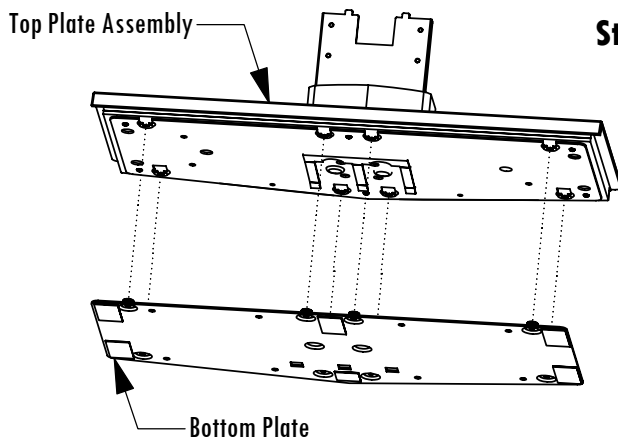

Protected under one or more of these U.S. Patent numbers: 3,291,432; 3,559,942; 3,724,798; DES:270,689; 4,613,109; 4,678,645; 4,852,842; DES:309,5624; 973,023; 5,169,114; 5,255,884; 5,310,159; 5,522,576; 5,621,614; Re:35,677; DES:398,834; 5,826,384; 5,941,492; 5,944,068; 6,060,661; 6,102,398; 6,138,704; 6,454,116; 6,761,276; 6,816,425; 6,816,425; 6,816,425