

SLELCD - Stealth Locking Furniture Mount for Flat Screens up to 26"* VESA 75mm, 100mm & 200mm Patterns

The SLELCD attaches to small and medium size flat screens up to 26"* with 75mm, 100mm or 200mm mounting patterns. The patented locking mechanism traps the monitor attaching screws providing security for your flat screen. Wood tapping screws are provided for quick and easy installation onto the counter top. An optional adhesive accessory is available for granite, marble or countertops that can not be drilled.

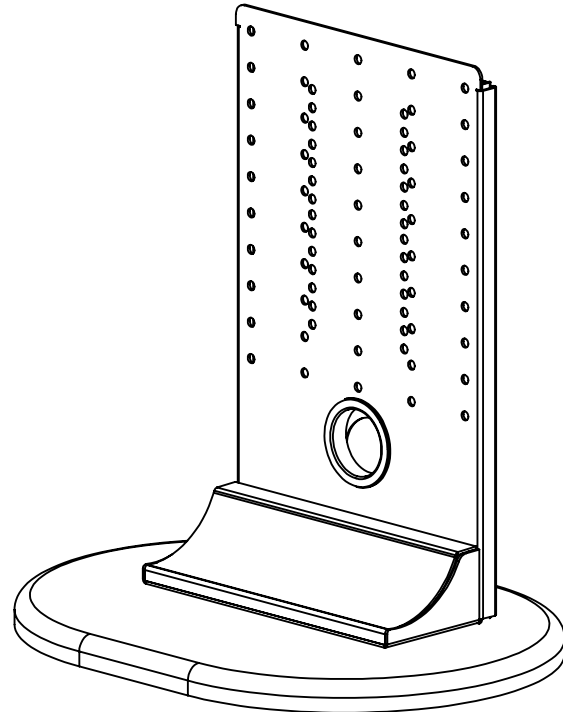

Features:

Available in black and silver finishes

Fits from 10" to 26"* flat panel monitors
* fits some 32" monitors depending on mounting pattern location and size

Universal mounting pattern fits 75mm, 100mm & 200mm VESA compatible monitors

Patented locking mechanism provides security for your flat screen

Decorative plastic cover hides swivel and locking mechanism

4mm, 5mm & 6mm monitor attaching hardware screws and studs are included

Convert from CRT Tube TVs to Flat Screen TVs with the same furniture swivel base

Swivel can be restricted to keep monitor from hitting the wall

Optional Accessories:

APSLEADS - Adhesive adapter for granite, marble or countertops that can not be drilled.

Maximum Load Limit:

50lbs (22.7kg)

Product Weight:

12.0lbs (5.5kg)

Shipping Weight:

13.8lbs (6.3kg)

Carton Dimensions:

16"L x 12"W x 5.5"H

Architectural Specification: The Furniture Mount shall be Lucasey model SLELCD and shall be located where indicated on the plans. It shall feature monitor attaching plates included compatible with VESA 75mm, 100mm and 200mm mounting patterns. Assembly and installation shall be done according to instructions provided by the manufacturer.



Furniture Base

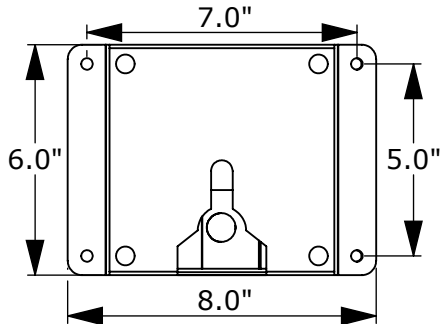

Top View

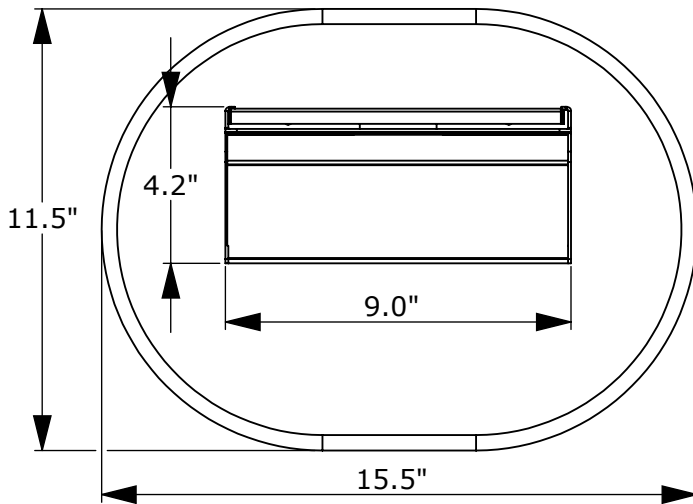

Bottom View

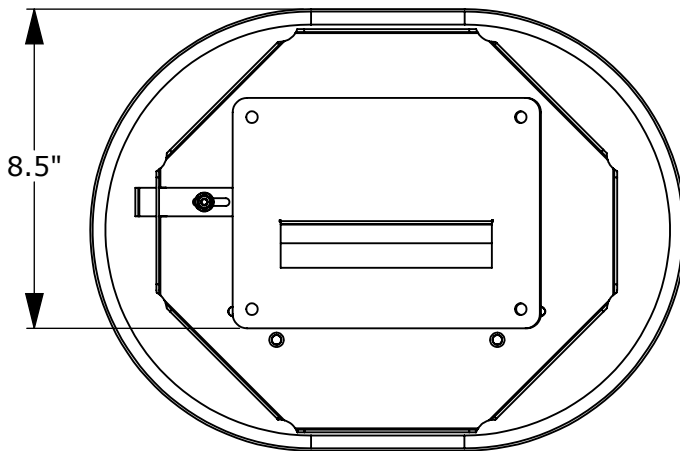

VESA Mounting Plate

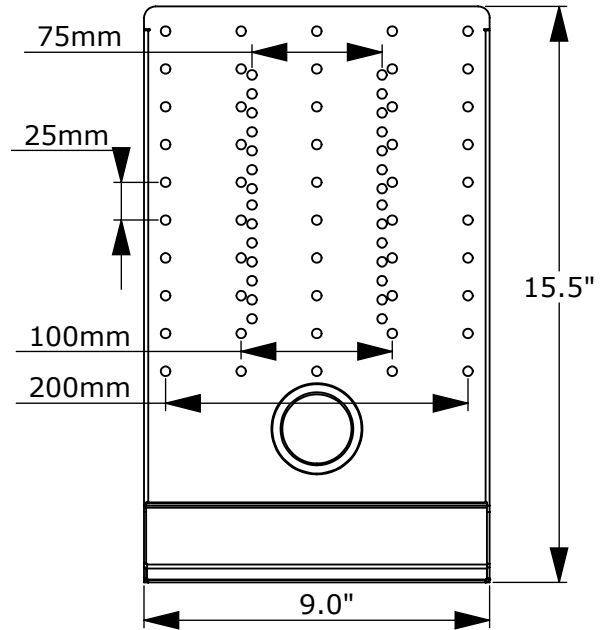

Side View

